

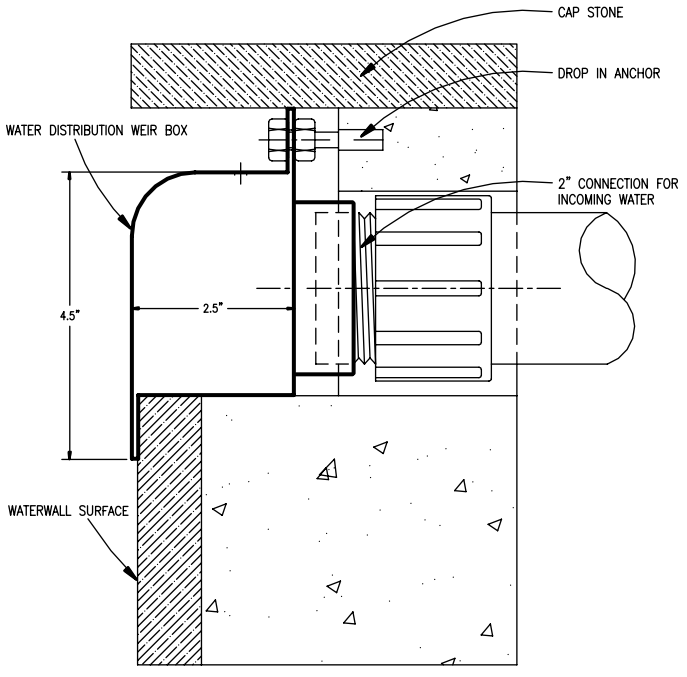

**191-2S Series
Waterwall Weir Box**

Function:

The **191-2S Series Water Wall Weir Boxes** are versatile and rugged in their design. The box discharges water evenly over a water wall of almost any length. Due to it's unique design, the Weir Boxes use very little water to create a classic effect.



Accessories shown in drawing: 2" Male Adapter with 2" incoming water line by installer.

Key Features:

- High quality Stainless Steel construction.
- Can be connected to form longer sections. Standard length is 4'.
- Low water usage.
- Fits many different applications, best suited for areas where space is limited.
- 2" Connection for incoming water from the side of the box.
- Must have 100% filtered water.

Every project is different and requires unique attention. Please consult a Hobbs sales associate when selecting which weir box is appropriate for your project. The installation above is of a typical installation and thus, dimensions and other factors are subject to change.

Recommended Flow Per Foot	Recommended Flow Per 4' Box	Shipping Weight
1 - 2 Gallons, 5 - 7 Gallon max.	5 - 7 Gallons, 10-12 Gallon max.	TBD