

420R Series

LED Light Fixture

Function:

The **420R Series Submersible Ring LED Light Fixture** is an ultra-thin, rugged fixture that provides vibrant color or all white light. It's unique design allows for several installation methods and placement possibilities. A spray effect can be placed in the center of the ring for maximum lighting in a submersed or flush mount grating application (see 180 Series Can Jets).



#420R-W Submersible Light: 12V, all white LED fixture with 120 bulbs.

#420R-C Submersible Light: 12V, Combination Red, Blue & Green automatically changing LED fixture with 120 bulbs.

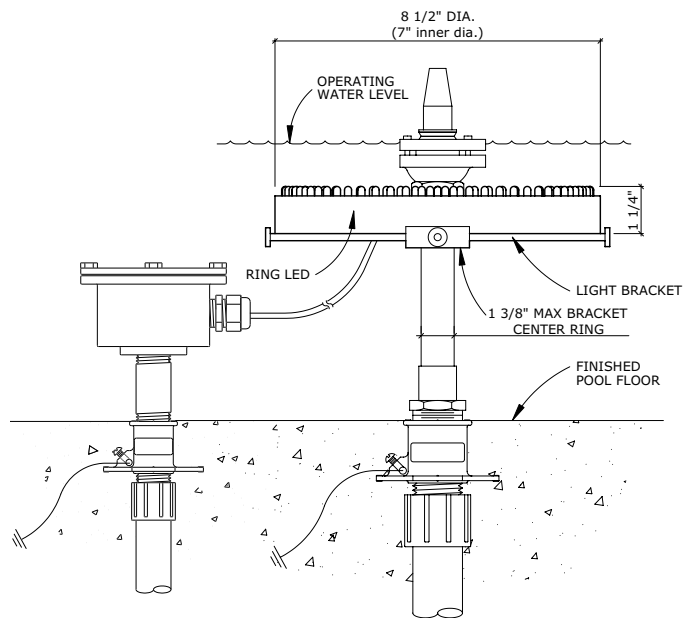

Key Features:

- 120 Ultrabright white, or combination red, blue & green automatically changing bulbs.
- 12 VAC, 5W. Supplied with 120V outdoor transformer if applicable to site specific installation.
- Fully potted, stainless steel construction
- Supplied with mounting bracket for attaching to submersed spray effect (as shown in drawing).
- 33 ft. submersible cord included.



Model	Order #	Description	Shipping Weight
420R-W	270-27881	Submersible, Free Standing or Jet Mounted, 12V, All White LED Fixture	2.0 lbs.
420R-C	270-27882	Submersible, Free Standing or Jet Mounted, 12V, Combo Red, Blue, Green Auto-Changing LED Fixture	2.0 lbs.

Accessories / Notes: Junction box and spray effect are not included and are only shown for illustration purposes.

Every project is different and thus, so are the lighting requirements. Please contact a Hobbs Sales Representative for assistance when specifying these parts.