

484 Series

Water Level Sensor

Function:

The **484 Series Water Level Sensor**, used in conjunction with a 487 Series Monitor and an electronic solenoid-type fill valve (sold separately), provides a safe method of electronically maintaining the fountain water level and providing low-water protection for submersible electrical equipment and/or fountain pumps, as required by the National Electric Code, Article 680.

When the water level drops, the Water Level Sensor and Monitor will signal the solenoid valve to open and refill the pool to the required level. If the solenoid valve is not notified and/or the water level continues to drop, the Low-Water Cut Off Sensor and Monitor will shut-off the electrical equipment (pumps and underwater lights). Both functions automatically return the controlled items to "normal" operating mode upon restoration of the proper water level.

The system utilizes solid state monitors and noncorroding sensors with stainless steel probes, resulting in no moving parts. Both the level control and cutoff functions are combined into one pool-mounted sensor with two probes. We normally provide these systems as part of a preassembled and tested package, with the appropriate monitor(s), relays and breakers built into the control panel for the fountain.



Key Features:

- Includes two nylon isolated, stainless steel probes and copper probe chamber.
- Housing and faceplate are cast bronze and utilize neoprene gasket and stainless steel fasteners.
- Housing has a 3/4" female N.P.T. bottom connection.

#484-111A Water Level Sensor: 3/4" N.P.T. bottom connection. Includes 50 feet of 18/3 type submersible cord

#484-111B Water Level Sensor: 3/4" N.P.T. bottom connection. Includes 100 feet of 18/3 type submersible cord

#484-111C Water Level Sensor: 3/4" N.P.T. bottom connection. Includes 150 feet of 18/3 type submersible cord

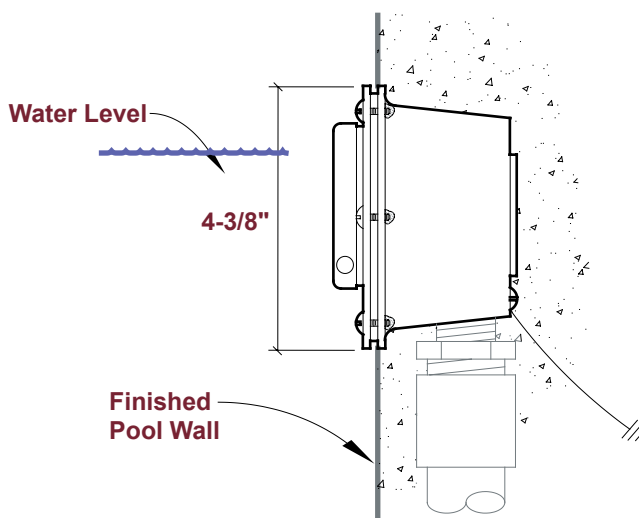

MODEL	ORDER #	DESCRIPTION	SHIP WEIGHT
484-111A	27495	In-Wall Water level sensor with 50 feet 16/3 cord.	10.0 lbs
484-111B	27496	In-Wall Water level sensor with 100 feet 16/3 cord.	13.0 lbs
484-111C	27497	In-Wall Water level sensor with 150 feet 16/3 cord.	16.0 lbs
487-3	27576	Water Level Monitor (Required for water level sensors)	2.0 lbs

H₂O
PARTS
a wm. hobbs ltd. company

Toll Free: 887.426.4622
Phone: 770.457.3000
Fax: 770.457.4225
www.hobbsfountains.com