

231 Series

Sump

#231-221 Series Sump:
8" diameter; 2" female
NPT bottom and side
connections; one 2" plug.

Function:

The **231 Series Sump** is our smallest sump and is installed flush in the pool floor. The fitting can serve a number of functions, but is typically used in one of the following ways:

1. Suction Sump - When used as a suction sump, the fitting prevents vortexing by forcing water to circulate across the pool floor. Vortexing allows air to enter the suction line, eventually shortening the pump life. Also, the improved water circulation caused by the sump helps keep the pool floor clean. The maximum designed flow rate when used as a suction sump is 60 GPM with a 16" water level.

2. Ballast Fitting - The fitting may be used as a ballast fitting for waterfalls, or as a dump line in fountains with our 492-Series Wind Compensation System. The maximum flow rate when used as a ballast fitting or dump line is 70 GPM with a 16" water level.

3. Equalizer Fitting - The fitting may be used as an equalizer between small pools with equal water levels. The maximum flow rate when used as an equalizer fitting is 20 GPM.

4. Pool Drain - As a second function to any of the above, the fitting can function as a small capacity (20 GPM) pool drain.



Key Features:

- Sump is injection molded, white cyclolac plastic with integral waterstop flange.
- Diverter plate is natural finish brass, and attaches with two brass screws.
- 2" female NPT bottom and side connections for versatility.
- Pipe connections are double tapered to provide leak-free joints from the inside, as well as the outside.

Brass Diverter Plate

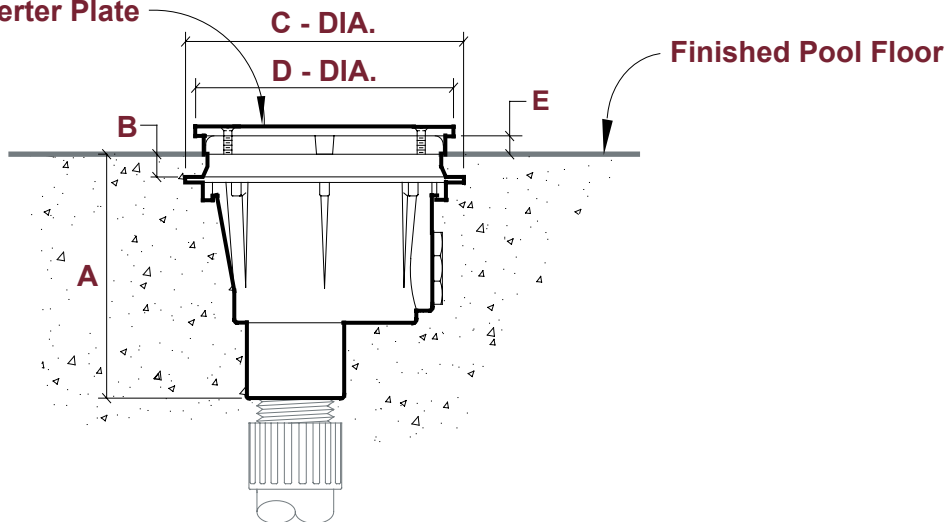

| Model | Order # | Description | A | B | C | D | E | Shipping Weight |
|---------|-----------|---|----------|------|--------|----|------|-----------------|
| 231-221 | 240-24022 | 8" Diameter sump with brass diverter plate. | 6-11/16" | 5/8" | 8-5/8" | 8" | 1/2" | 7.0 lbs. |

Toll Free: 887.426.4622
Phone: 770.457.3000
Fax: 770.457.4225
www.hobbsfountains.com