



Function:

The **700e-Silver Series Display Pad** is identical to the Bronze Series in performance with the only exception being the use of schedule 80 PVC piping where possible. It features high quality components and reliable construction. This system provides one suction and one discharge for large spray effects and water fountains.

- Standard system includes selected pump size, discharge assembly with 6" waffer-style check valve and infinite position butterfly valve, and suction assembly with a 6" 10 position butterfly valve. *NOTE: The 700e-051-3-S system has 4" discharge and suction assemblies.*
- Fill / Level Manifold is a separate, optional item.
- Control panel requirements vary depending on pump selection. A control panel is required for all systems.

PUMP INFORMATION:

5 HP; 3 Phase; 208-230/460V;
 Delivers 195 GPM at 60 feet of head, 155 GPM at 80 feet of head, 100 GPM at 95 feet of head.

5 HP; 3 Phase; 208-230/460V;
 Delivers 350 GPM at 30 feet of head, 295 GPM at 50 feet of head, 205 GPM at 70 feet of head.

7-1/2 HP; 3 Phase; 208-230/460V;
 Delivers 503 GPM at 30 feet of head, 450 GPM at 50 feet of head, 370 GPM at 70 feet of head.

10 HP; 3 Phase; 208-230/460V;
 Delivers 625 GPM at 30 feet of head, 570 GPM at 50 feet of head, 375 GPM at 90 feet of head.

15HP; 3 Phase; 208-230/460V;
 Delivers 640 GPM at 50 feet of head, 590 GPM at 70 feet of head, 330 GPM at 120 feet of head.

20 HP; 3 Phase; 208-230/460V;
 Delivers 730 GPM at 50 feet of head, 690 GPM at 70 feet of head, 450 GPM at 120 feet of head.

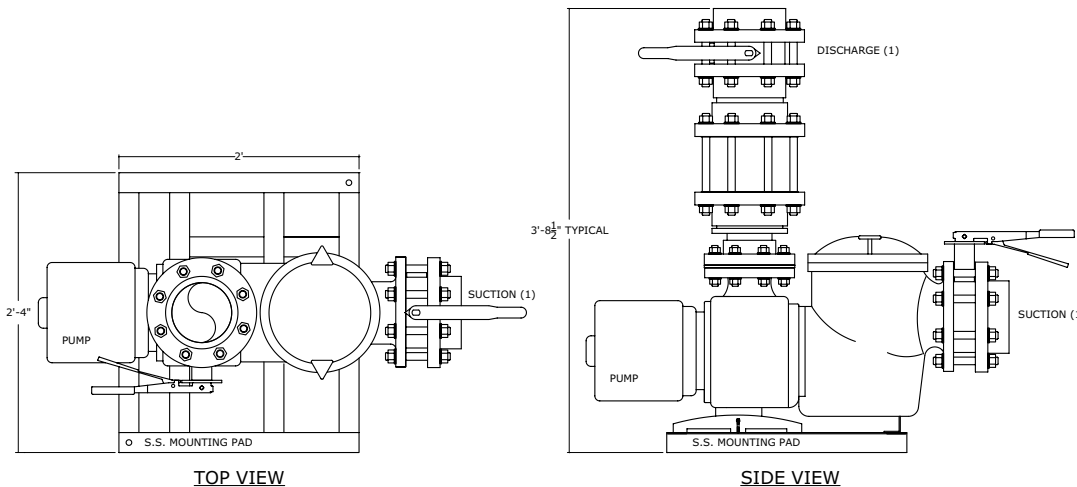

Shown with bronze 5 through 20 HP pump.

Model	Order #	Description
700e-051-3-S	680-69702	Silver Series, 5 HP, 3φ, Display Pad (Thermoplastic Pump) - 4" discharge / 4" suction
700e-050-3-S	680-69696	Silver Series, 5 HP, 3φ, Display Pad (Bronze Pump) - 6" discharge / 6" suction
700e-075-3-S	680-69697	Silver Series, 7-1/2 HP, 3φ, Display Pad (Bronze Pump) - 6" discharge / 6" suction
700e-100-3-S	680-69698	Silver Series, 10 HP, 3φ, Display Pad (Bronze Pump) - 6" discharge / 6" suction
700e-150-3-S	680-69699	Silver Series, 15 HP, 3φ, Display Pad (Bronze Pump) - 6" discharge / 6" suction
700e-200-3-S	680-69700	Silver Series, 20 HP, 3φ, Display Pad (Bronze Pump) - 6" discharge / 6" suction
Control Panel Options		
ePanel1	940-94992	1φ eSeries Control Panel without Fill / Level Manifold
ePanel2	940-95005	1φ eSeries Control Panel with Fill / Level Manifold
ePanel3	940-95003	3φ eSeries Control Panel without Fill / Level Manifold
ePanel4	940-95002	3φ eSeries Control Panel with Fill / Level Manifold
Optional Equipment		
700e-BS	680-69620	3/4" Fill / Level Manifold Assembly

Toll Free: 887.426.4622
 Phone: 770.457.3000
 Fax: 770.457.4225
www.hobbsfountains.com