

Function:

The **270 Series Floating Skimmer** has a unique design that allows it to move up and down on a suction line. Typically placed in deep, underground reservoirs, this skimmer is best suited for applications where water level changes are severe and a wall embedded unit will not work. It features a 360° weir edge allowing it to pull debris from the water's surface from all sides. The nominal required flow is X to XX GPM. The skimmer requires a 3" PVC pipe connection.

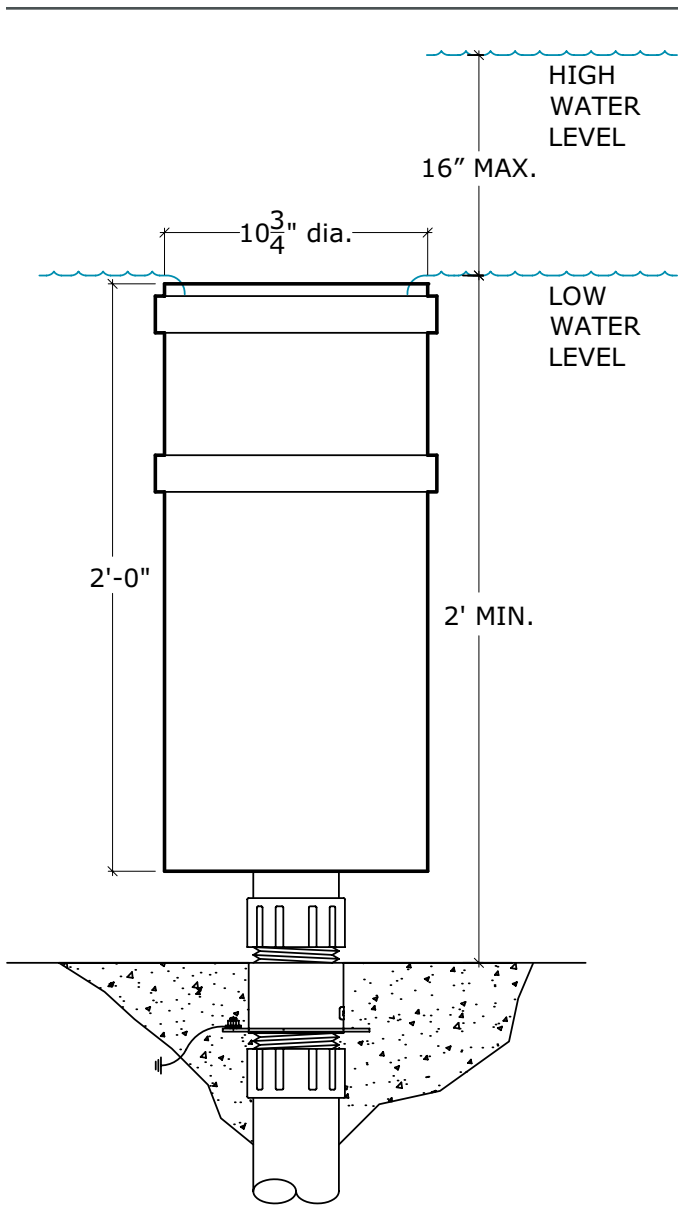

Key Features:

- White PVC construction
- 16" vertical movement or multiple water depths
- 10.75" dia., 360° weir edge

Model	Order #	Description	Shipping Weight
270-10	240-24720	10" Floating Skimmer, 3" connection	10.0 lbs