



Function:

The **871 Series WET-PAK** submersible pump kit offers a unique alternative to the traditional above-floor submersible fountain pumping system by moving the pump and plumbing from plain view and into a flush mount, pre-fabricated, stainless steel pump pit. This reduces clutter on the fountain floor leaving your eyes to focus on the fountain feature, not the pumping system.

The WET-PAK also features a removable fibermat filter element that screens debris from the water, preventing clogging of the pump and piping. And to protect your investment in case someone enters the fountain, all WET-PAKS come with a fiberglass grating cover that can hold the weight of a person.

WET-PAK Pump Kits arrive at the job-site pre-assembled with pump, cord seal(s) and/or underwater junction box, discharge ball valve, drain fitting with plug, and 3/4" fitting for connection of fill piping. Once the plumbing and electrical connections have been made, and the fountain structure poured, the WET-PAK is ready for operation.

Control of the WET-PAK is typically handled by mounting a mechanical time clock or simple on/off switch in a convenient location near the fountain. Contact our office for order and price information on electrical controls. (NOTE: All power to the WET-PAK must be protected by a Class A ground fault interrupter device).



Key Features:

- 14 gauge stainless steel shell, approximately 2'-6" long x 1'-1" wide x 1'-1" deep.
- 1-1/2" drain connection and brass plug.
- Black fibermat screen element conceals unit in basin floor, and helps prevent debris clogs in pump.
- Fiberglass grating supports fibermat and provides weight bearing protection for internal components.
- Single polyamide cord seal or bronze junction box with two or three cord seals, duct seal, and potting compound.
- True-union PVC discharge ball valve to adjust water flow to the fountain display
- Installation cut-sheets available.

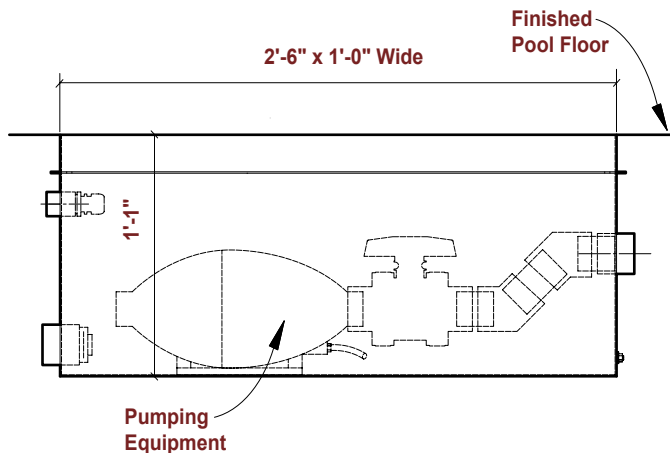

871 Series

Wet-PAK Kit

#871-1070X WET-PAK Pump Kit: 1/7 HP, 120 Volt, Single Phase Motor.

#871-1030X WET-PAK Pump Kit: 1/3 HP, 120 Volt, Single Phase Motor.

#871-1230X WET-PAK Pump Kit: 2/3 HP, 120 Volt, Single Phase Motor.

#871-1100X WET-PAK Pump Kit: 1 HP, 115 Volt, Single Phase Motor.

X=A, B, or C. Please specify when ordering. See below for choices.

Models ending in 'A' include 1 cord seal for electrical connection to the pump.

Models ending in 'B' include 2 cord seals with a bronze junction box and potting compound for electrical connection to the pump and 1 submersible light fixture (light fixture sold separately).

Models ending in 'C' include 3 cord seals with a bronze junction box and potting compound for electrical connection to the pump and 2 submersible light fixtures (light fixtures sold separately).